

SERVICE SOLUTIONS // HOW TO

HOW TO DISASSEMBLE THE GEARBOX ON RPS-S

1. Remove the screws from the flange of the gearbox (**no. 27**) to remove the engine (**no. 39**)
2. Remove the screws from the flange of the sawblade (**no. 24**) remove the flange (**no. 9**) and then remove the sawblade (**no. 34**)
3. Remove the screws (**no. 23**) from the flange and remove this (**no. 8**) allowing you to extract the gearbox from the main body.
4. Remove the screws (**no. 43**) and open the cover (**no. 13**)
5. Remove the support of the water distributor (**no. 16**)
6. Remove the screws (**no. 40**) and the locating pins (**no. 52**)
7. Now you can take away the gearbox from the main body

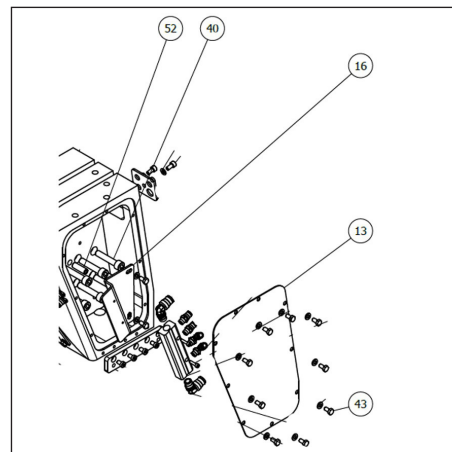
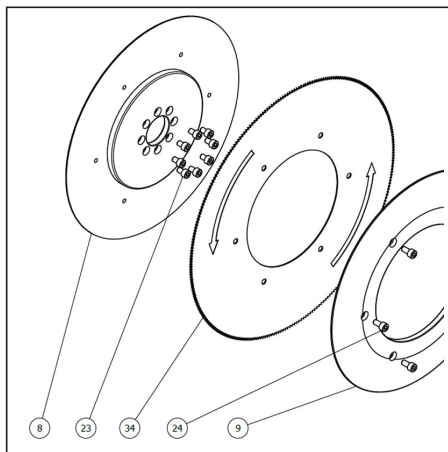
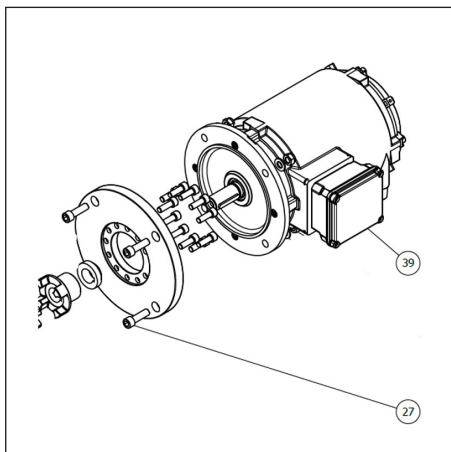

CONTACT

Central/Eastern Europe
+49 252 185 070
service.de@frontmatec.com

Northern Europe, Kolding
+45 36 999 099
service.kol.dk@frontmatec.com

Northern Europe, Tandslet
+45 74 407 644
service.tan.dk@frontmatec.com

Southern Europe
+34 932 643 800
service.es@frontmatec.com

Western Europe
+31 886 294 000
service.nl@frontmatec.com