

SERVICE SOLUTIONS // HOW TO

LIFE PROLONGING TIPS WHEN RENOVATING THE HAM-DIVIDER GEARBOX ON YOUR AUTOLINE BUNGDROPPER

When you renovate the axle with the crown wheel with new bearings.

1. The housing for the crown wheel must be filled with grease before reassembling the gearbox - position A
2. Push shaft - position B up to the crown wheel and then take it 1 mm back. Now lock with the bolt - position C
3. Tighten position C - IMPORTANT - there must be a little space between the gear wheel teeth - position D

Additional tip

4. If the bushing on the dummy part needs to be replaced, you can use a 16 mm threading tap to pull it up - position E

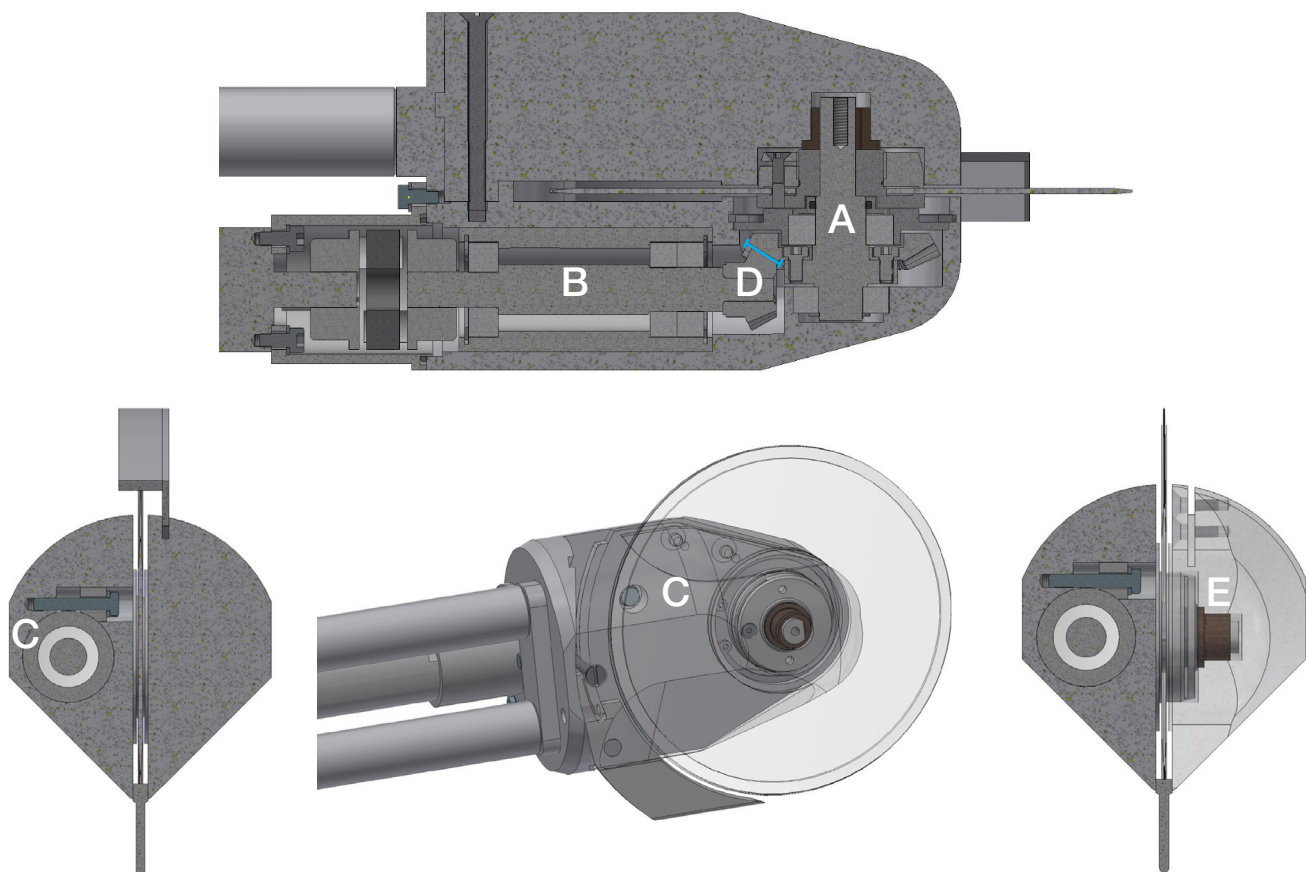

Bronze bushing on dummy - part no.: 4001010645

Renovation kit - crown wheel and bracket - part no. 4001070209

CONTACT

Central/Eastern Europe
+49 252 185 070
service.de@frontmatec.com

Northern Europe, Kolding
+45 36 999 099
service.kol.dk@frontmatec.com

Northern Europe, Tandslet
+45 74 407 644
service.tan.dk@frontmatec.com

Southern Europe
+34 932 643 800
service.es@frontmatec.com

Western Europe
+31 886 294 000
service.nl@frontmatec.com